

Parker Sidney PH20A

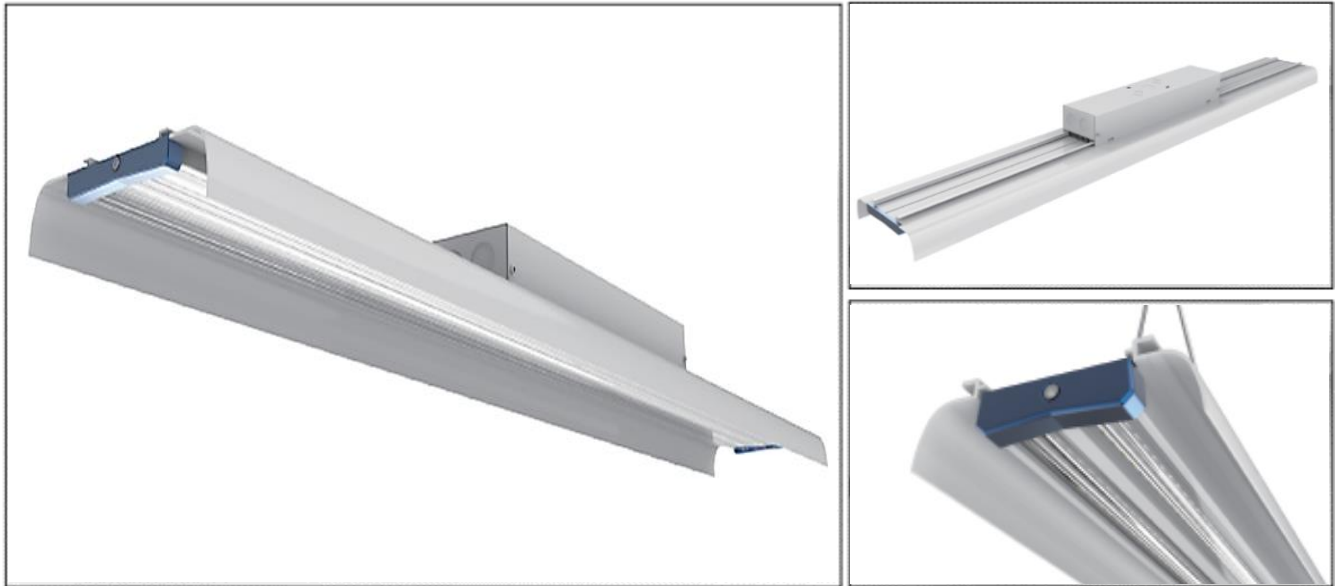

Linear LED High Bay Luminaire with Optional Dimming and Linkability

Parker Sidney PH20A is an ambient linear LED product with high efficiencies of 160 lm/W, an aluminum body to enhance heat dissipation, and flexible installation supporting either surface or suspended mounting brackets. Used in a wide variety of industrial and commercial environments such as warehouses, parking lots, stairwells and many more.

FEATURES

- IP40 / IK08
- SDCM 3 or 6
- Up to 160 lm/W
- Linkable Option
- Non-Flicker
- Fast Fit and Zero Maintenance
- 5 Year Warranty
- Wide Use in Commercial and Industrial Applications
- Emergency | Microwave | Dimmable Available

APPLICATION

- **INDUSTRIAL**
Warehouses, Production Halls, Parking Areas, Stairwells
- **EDUCATION**
Classrooms, Cafeterias, Auditoriums, Sports Halls
- **SEMI-OUTDOOR**
Car Garages, Pools, Airports, Train/Bus Stations, Gas Stations, Parks, Toll Stations
- **SHOP & RETAIL**
Shopping Malls, Supermarkets, Retail Stores
- **ARCHITECTURAL**
Exhibition Centers, Libraries, Museums, Concert Halls



SIZE

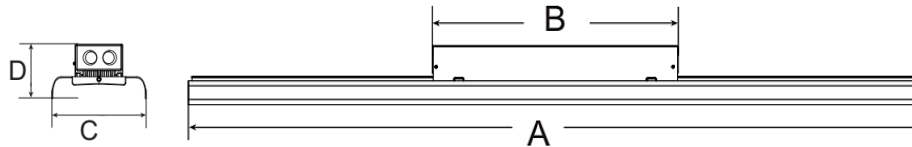

Model No.	Size A (feet)	Size B (inches)	Size C (inches)	Size D (inches)
PH20A	4 FT	15.75"	6.7"	4"

SPECIFICATIONS

MODEL	POWER (W)	LUMENS	lm/W
PH20A / 4FT	80	12800	160
PH20A / 4FT	120	19200	160
PH20A / 4FT	150	24000	160

Notes: All lumens based on 40000K Ra: 70
 All values in +25°C ambient temperature,
 luminous flux tolerance +-5%,
 output power tolerance +-5%.

TECHNICAL PRODUCT INFORMATION

- Operating: -30~+50°C
- Storage: -40~+85°C
- CRI Range: 70 / 80 / 90
- Certification: UL
- Beam Angle: 30° / 60° / 90°
- CCT Range: 3000K | 4000K | 5000K | 6500K
- AC Input: 100-277V 50/60Hz
- Light Efficiency: 160 lm/W
- Size: 4-foot length
- Indoor Use Only: IP40 & IK08
- Recommended Installation Height: 19.5-49ft

Function: Dimmable Linkable Microwave
 Dimming to be 0-10V

ACCESSORIES

Suspension Bracket

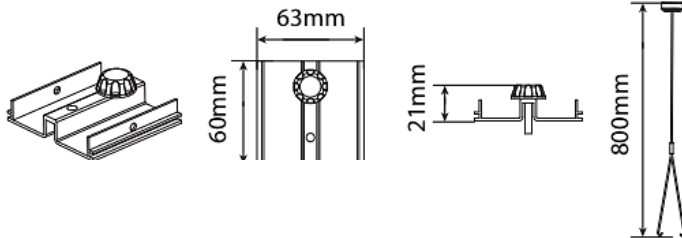

Linkable Bracket

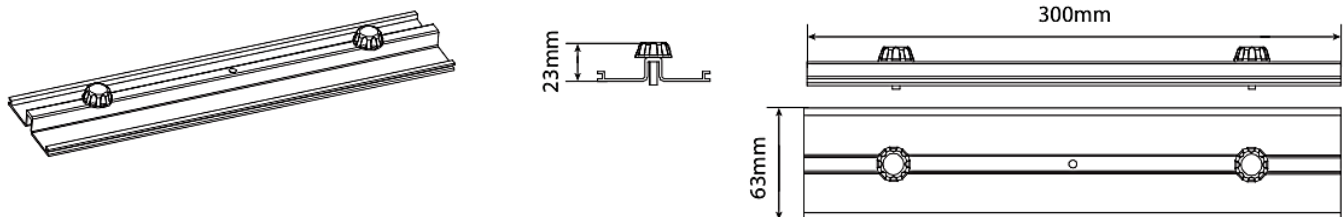



INSTALLATION

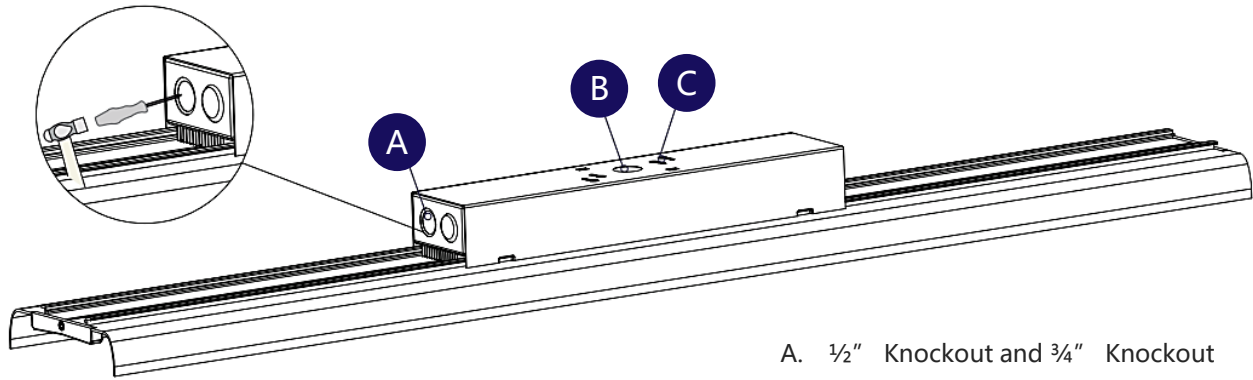

- A. 1/2" Knockout and 3/4" Knockout
- B. The Rear Knockout
- C. Wire Box Cover Installation

Standard Line Installation

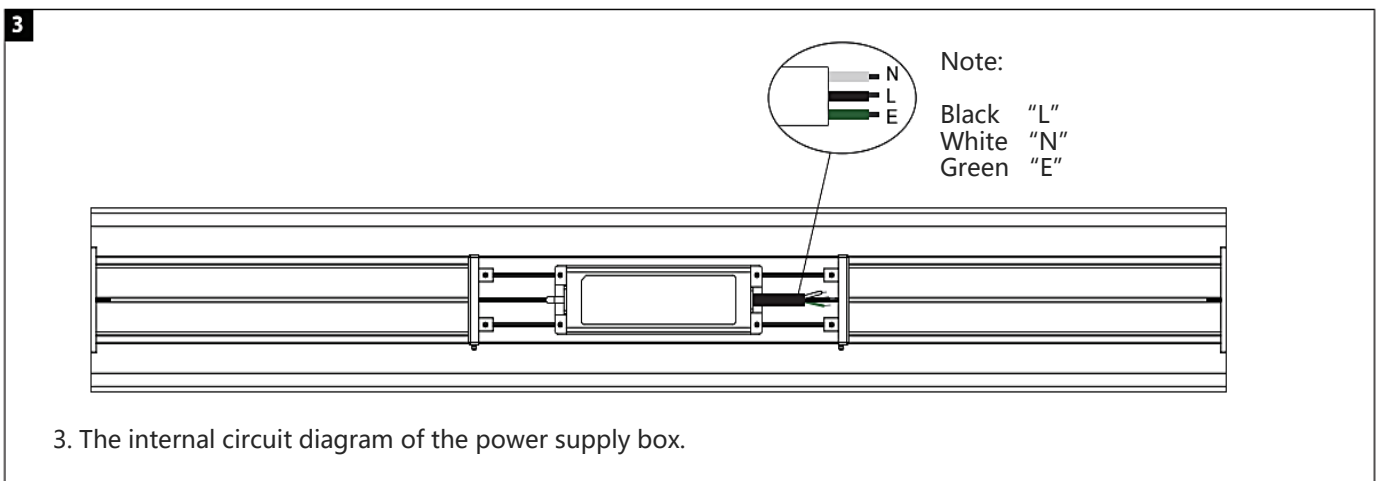
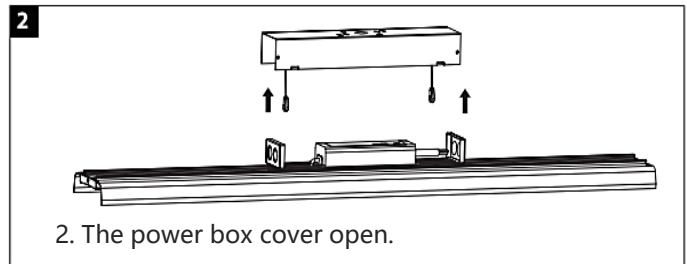
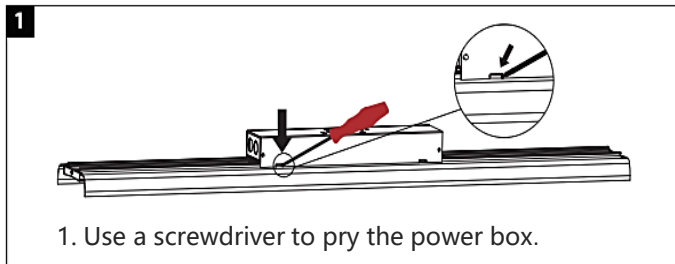



INSTALLATION

Ceiling Mounted Installation

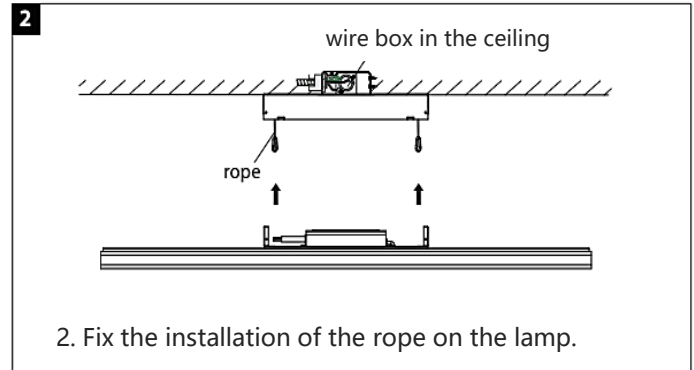
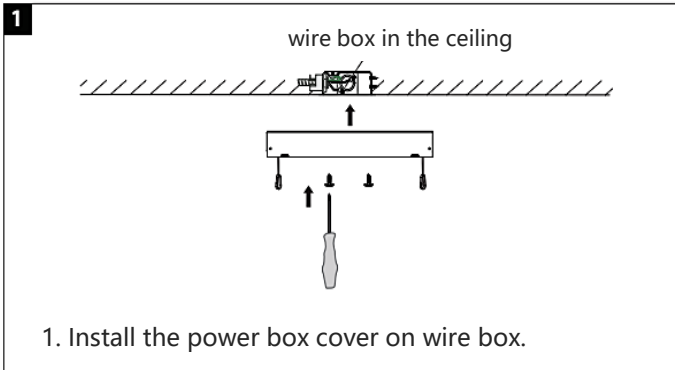

Suspension Mounted Installation

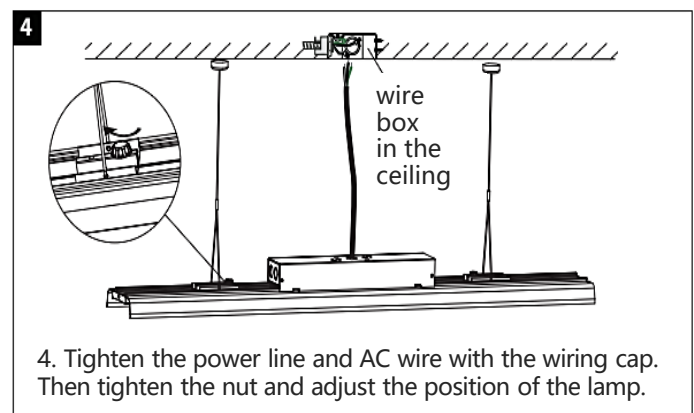
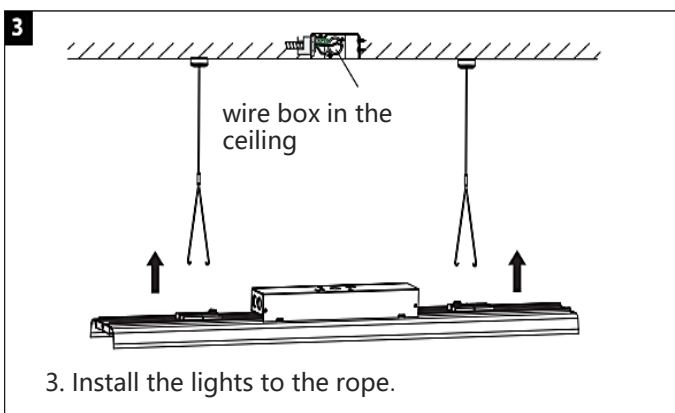
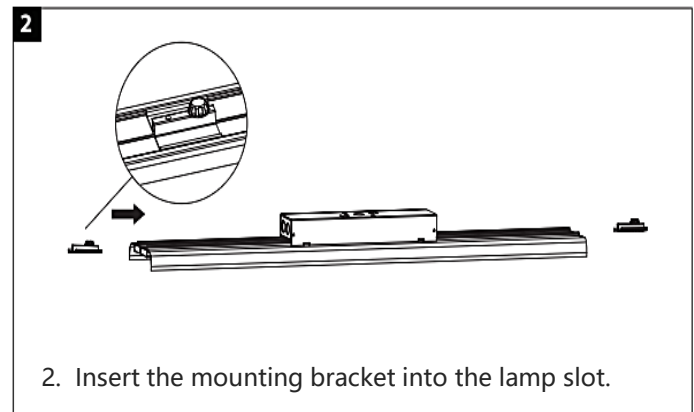
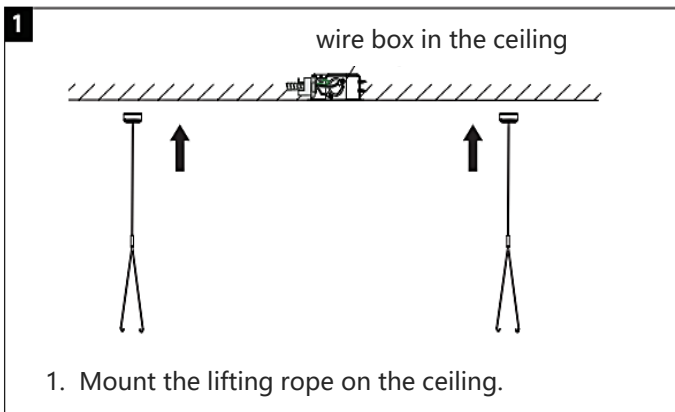



INSTALLATION

Linkable Line Installation

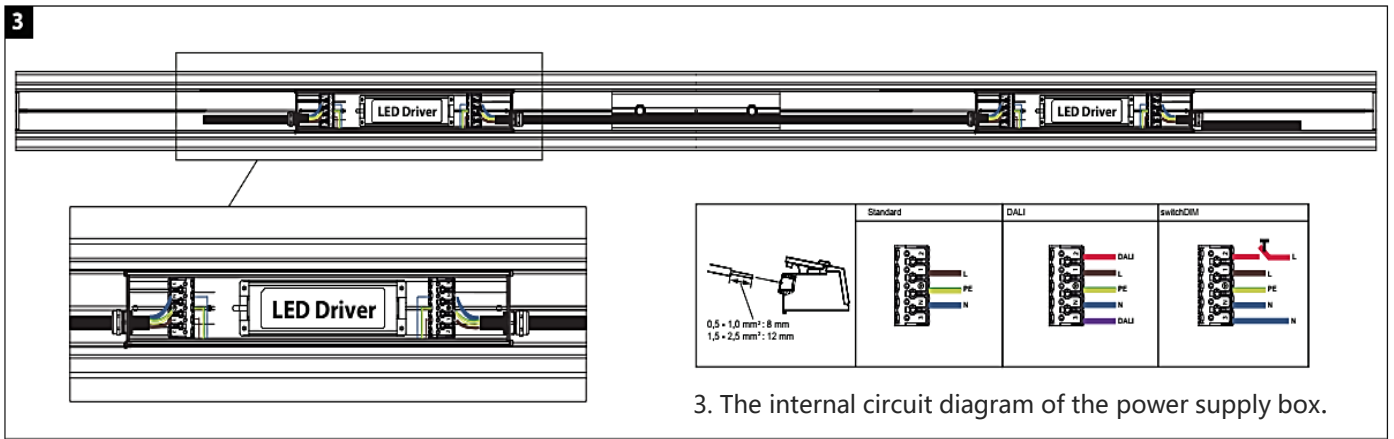
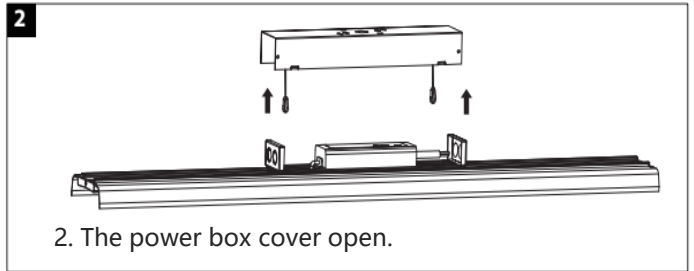
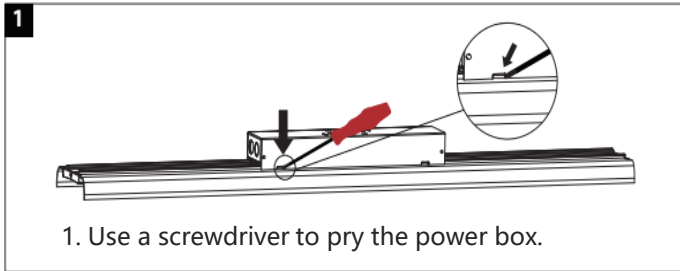

Linkable Installation



Linkable Bracket

